



VESTIL MANUFACTURING CORP.

2999 North Wayne Street, P.O. Box 507, Angola, IN 46703
 Telephone: (260) 665-7586 -or- Toll Free (800) 348-0868
 Fax: (260) 665-1339
www.vestilmfg.com e-mail: sales@vestil.com

**CR-SERIES CARPET POLES
 INSTRUCTION MANUAL**



Receiving instructions:

After delivery, IMMEDIATELY remove the packaging from the carpet pole in a manner that preserves the packaging and maintains the orientation of the product in the packaging; then inspect the product closely to determine whether it sustained damage during transport. **If damage is discovered during the inspection, immediately record a complete description of the damage on the bill of lading.** If the product is undamaged, discard the packaging.

NOTES:

- 1) Compliance with laws, regulations, codes, and non-voluntary standards enforced in the location where the product is *used* is exclusively the responsibility of the owner/end-user.
- 2) VESTIL is **not liable** for any injury or property damage that occurs as a consequence of failing to apply either:
 a) Instructions in this manual, or b) information provided on labels affixed to the product. Neither is Vestil responsible for *any* consequential damages sustained as a result of failing to exercise sound judgment while assembling, installing, using or maintaining this product.

Table of Contents

Hazard Identification: Explanation of Signal Words..... 2
 Safety Recommendations.....2 - 3
 Product Specifications.....3
 FIG. 1: CR (class 2 carriage) welded carriage bracket, exploded parts diagram & bill of materials..... 3
 FIG. 2: CR (class 3 carriage) welded carriage bracket, exploded parts diagram & bill of materials4
 Carpet ram installation..... 5
 Use instructions..... 5
 Inspections..... 6
 Maintenance..... 7
 Label Placement Diagram.....7
 Limited Warranty.....8

Signal Words:

This manual uses SIGNAL WORDS to indicate the likelihood of personal injuries, as well as the probable seriousness of those injuries, if the product is misused in the ways described. Other signal words call attention to uses of the product likely cause property damage.

The signal words used appear below along with the meaning of each word:



Identifies a hazardous situation which, if not avoided, **WILL** result in **DEATH** or **SERIOUS INJURY**. Use of this signal word is limited to the most extreme situations.



Identifies a hazardous situation which, if not avoided, **COULD** result in **DEATH** or **SERIOUS INJURY**.



Indicates a hazardous situation which, if not avoided, **COULD** result in **MINOR** or **MODERATE** injury.



Identifies practices likely to result in product/property damage, such as operation that might damage the product.

Each person who assembles, installs, uses, or maintains this product should read the entire manual **in advance and fully understand the directions**. If after reading the manual you do not understand an instruction, ask your supervisor or employer for clarification, because failure to adhere to the directions in this manual might result in serious personal injury.

Safe Use Recommendations:

Vestil diligently strives to identify foreseeable hazards associated with the use of its products. However, material handling is inherently dangerous and no manual can address every conceivable risk. The end-user ultimately is responsible for exercising sound judgment at all times.



Electrocution might result if any part of the pole, fork truck, or carpet roll contacts electrified wires. Reduce the likelihood of electrocution by applying **common sense**:

- DO NOT *contact* electrified wires with any part of the ram, the fork truck, or the roll of carpet;
- Before using the carpet ram, inspect the usage area implement precautions that account for electrical hazards.



Improper use of this product might result in serious personal injuries:

- ***Failure to read and understand the entire manual before assembling, installing, using or servicing the product is a misuse of the product.*** Read the manual to refresh your understanding of proper use and maintenance procedures.
- DO NOT exceed the maximum rated load (see Label 287 on product; also shown on p. 7).
- Inspect the carpet pole before each use.
 - A. DO NOT use this device if the inspection reveals structural damage. Examples of structural damage include: 1) broken, missing, or deformed carriage brackets; 2) damaged or deformed latch mechanism; 3) cracked welds; 4) enlarged openings for fasteners (i.e. pins and bolts used to fasten the pole to the carriage weldment; 5) corrosion, severe wear, or other condition that affects the ability of the product to support a roll of carpet. Replace each part that fails to pass an inspection, and DO NOT use the product until it is fully restored to normal condition.
 - B. DO NOT use the product if any unusual noise or movement occurs during use. Immediately unload the carpet ram, remove the unit from service, and notify your supervisor & maintenance personnel about the issue.
- Before attaching the carpet ram to the carriage of your fork lift, inspect the carriage and confirm that all parts are structurally sound and in nominal condition.
- Always test the soundness of the connection between the carriage weldment of the carpet ram and the carriage of the fork truck before driving the fork truck with a loaded carpet pole, by lifting the roll just a few inches off of the ground. Load swing should be minimal and the carpet pole should not shift. If the load is not stable while supported by the pole, return it to the ground and use another means to transport the roll of carpet.
- ALWAYS apply all rules governing use of fork lift attachments applied at your work site.
- DO NOT remove or obscure any label. Verify the placement and legibility of all labels as shown in the Label Placement Diagram on p. 7. DO NOT use this device UNLESS all product labels are readable and undamaged.
- DO NOT ride or sit on the carpet pole.
- DO NOT use the carpet pole to push another object. Only use the product to transport a roll of carpet.
- ONLY use this forklift attachment on firm, level, even ground.

•DO NOT leave elevated rolls of carpet unattended. Always move the roll to its desired location, remove it from the carpet pole and properly immobilize it before leaving the roll unattended.

WARNING (Continued from p. 2)

•DO NOT modify the carpet pole in any way UNLESS you first obtain written approval from Vestil. **Unauthorized modifications automatically void the limited warranty (see p. 8) and might make the product unsafe to use.**

NOTICE

Proper use, maintenance, and storage are essential for this product to function properly.

- Always use this product in accordance with the instructions in this manual and consistent with any training relevant to forklift attachments.
- Follow and apply the inspection and maintenance procedures on p. 7-8.

Product Specifications:

CR-series Carpet Poles					
Model	Pole Length	Overall length	Pole diameter	Capacity	Net Weight
CR-108-2	108 ¹ / ₂ " (275.6cm)	114 ¹ / ₄ " (290.2cm)	2 ³ / ₄ " (~7cm)	2,500 (~1136kg)	278.7 (~126.7kg)
CR-120-2	120 ¹ / ₂ " (306.1cm)	126 ¹ / ₄ " (320.7cm)	2 ³ / ₄ " (~7cm)	2,200 (~1000kg)	298.9 (~135.9kg)
CR-144-2	144 ¹ / ₂ " (367.0cm)	150 ¹ / ₄ " (381.6cm)	2 ³ / ₄ " (~7cm)	1,800 (~818kg)	339.3 (~154.2kg)
CR-108-3	108 ¹ / ₂ " (275.6cm)	114 ¹ / ₄ " (290.2cm)	2 ³ / ₄ " (~7cm)	2,500 (~1136kg)	294.9 (~134.1kg)
CR-120-3	120 ¹ / ₂ " (306.1cm)	126 ¹ / ₄ " (320.7cm)	2 ³ / ₄ " (~7cm)	2,200 (~1000kg)	315.1 (~143.2kg)
CR-144-3	144 ¹ / ₂ " (367.0cm)	150 ¹ / ₄ " (381.6cm)	2 ³ / ₄ " (~7cm)	1,800 (~818kg)	355.6 (~161.6kg)

FIG. 1: Exploded parts diagram for Class 2 carriage CR-series carpet poles with welded lower carriage clamp

Torque specifications for clamp fasteners:

Item no. 2 (pole mounting bolts; ⁵/₈ in. – 11 x 6in. grade 8 SHCS bolt) should be fastened to hex nuts (item no. 3) with 238 ft*lbs. of torque.

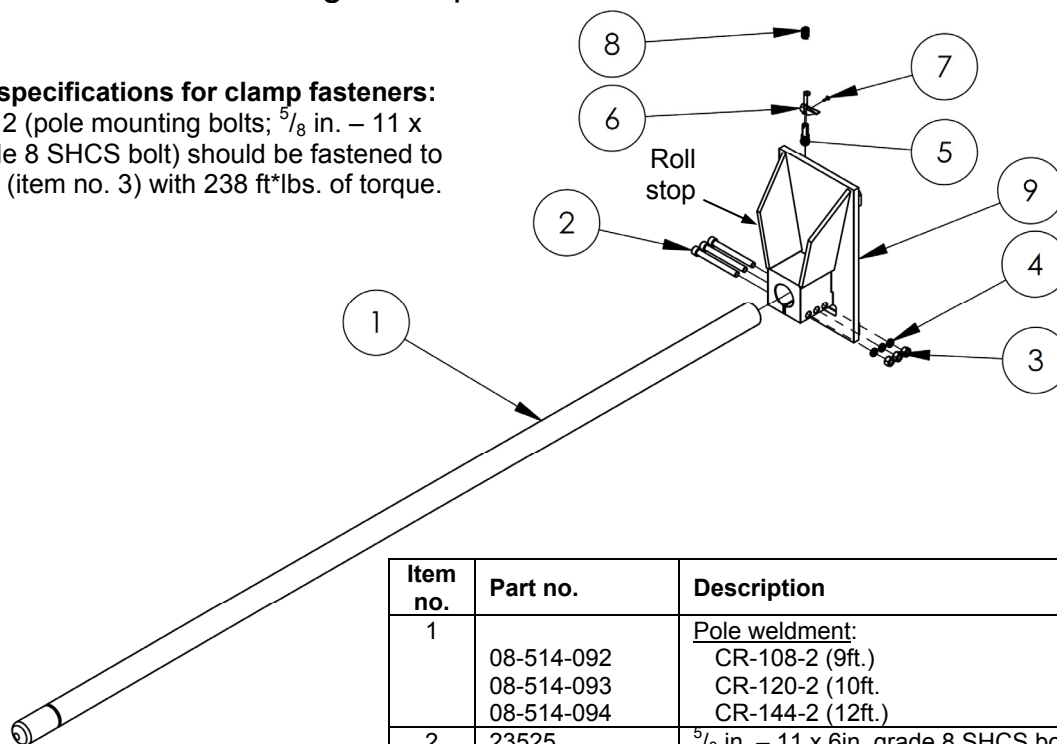

Item no.	Part no.	Description	Quantity
1	08-514-092	Pole weldment: CR-108-2 (9ft.)	1
	08-514-093	CR-120-2 (10ft.)	1
	08-514-094	CR-144-2 (12ft.)	1
2	23525	⁵ / ₈ in. – 11 x 6in. grade 8 SHCS bolt	3
3	36414	⁵ / ₈ in. – 11 grade 8 UNC hex nut	3
4	33692	⁵ / ₈ in. high collar lock washer	3
5	08-145-021	Latch pin	1
6	08-145-020	Latch lever	1
7	08-145-022	Latch rivet	1
8	08-146-004	Latch spring	1
9	08-538-001-002	Carriage backplate weldment	1

FIG. 2: Exploded parts diagram for Class 3 carriage CR-series carpet poles with welded carriage clamp

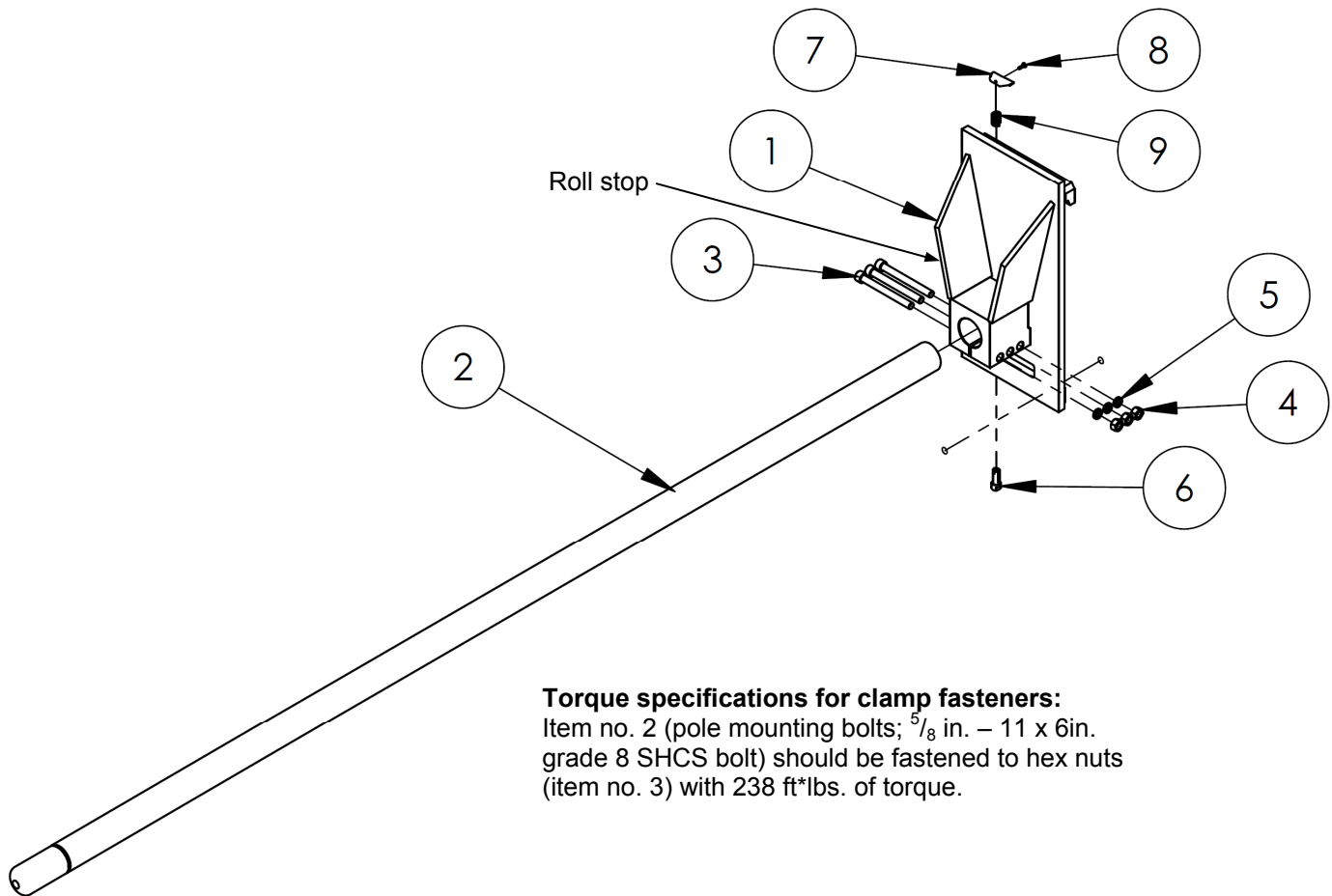

Torque specifications for clamp fasteners:

Item no. 2 (pole mounting bolts; $\frac{5}{8}$ in. – 11 x 6in. grade 8 SHCS bolt) should be fastened to hex nuts (item no. 3) with 238 ft*lbs. of torque.

Item no.	Part no.	Description	Quantity
1	08-538-002	Carriage backplate weldment	1
2	08-514-092	Pole weldment: CR-108-3 (9ft.)	1
	08-514-093	CR-120-3 (10ft.)	1
	08-514-094	CR-144-3 (12ft.)	1
3	23525	$\frac{5}{8}$ in. – 11 x 6in. grade 8 SHCS bolt	3
4	36414	$\frac{5}{8}$ in. – 11 grade 8 UNC hex nut	3
5	33692	$\frac{5}{8}$ in. high collar lock washer	3
6	08-145-021	Latch pin	1
7	08-145-020	Latch lever	1
8	08-145-022	Latch rivet	1
9	08-146-004	Latch spring	1

Carpet ram installation:

Step 1: Remove the tines from the lift truck carriage.

Step 2: Referring to the diagram below, rotate the latch lever to the open position. Set the end of the upper carriage bracket opposite the lower carriage bracket on the upper carriage crossbar of your lift truck.

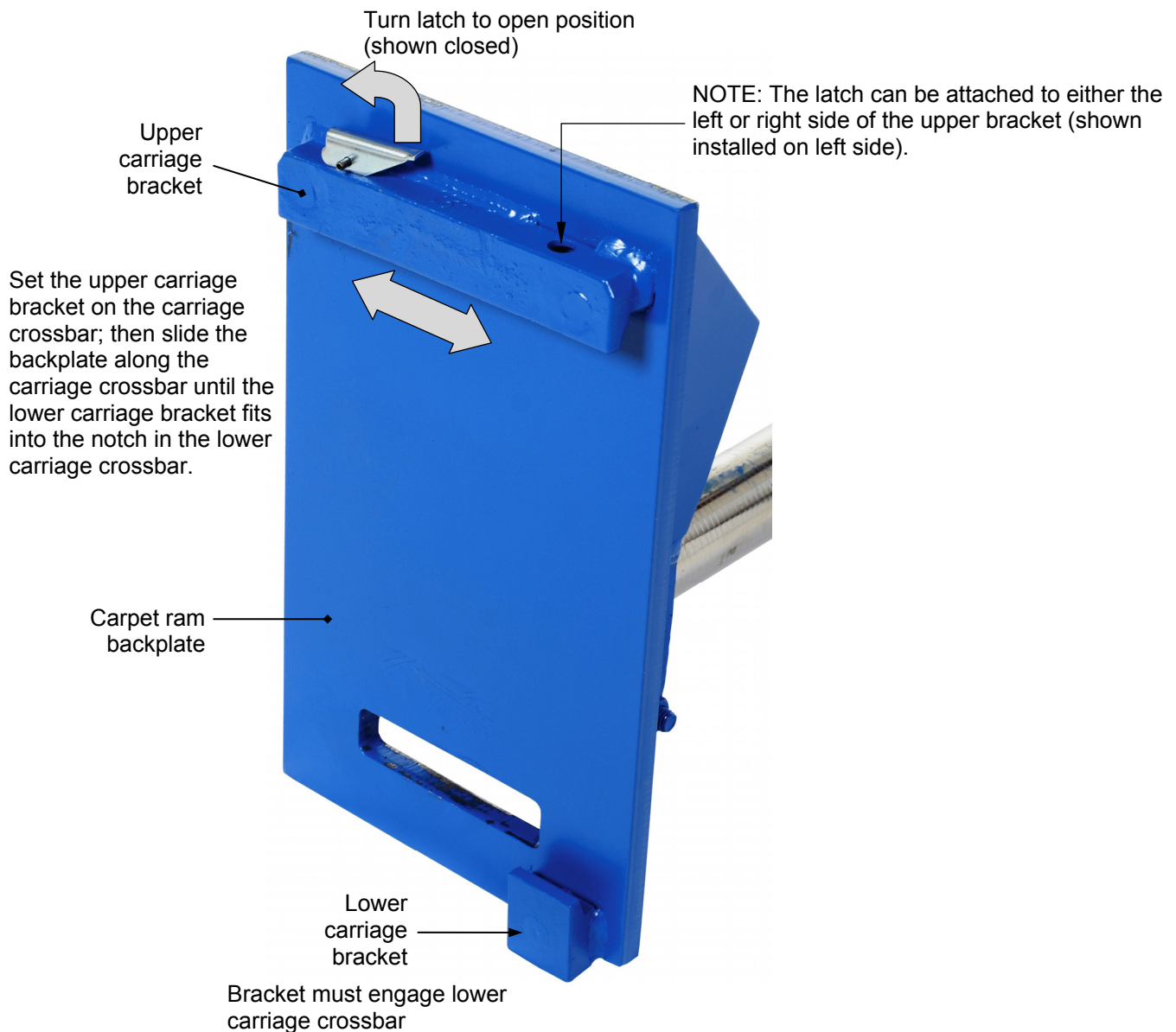

Step 3: Slide the backplate along the carriage crossbar adjusting its position to allow the lower carriage bracket to fit into the notch in the lower carriage crossbar (of the forklift). The notch is probably located at the center of the crossbar. Next, slide the backplate to the left or right as necessary to center the carpet ram on the carriage.

Step 4: Secure the carpet ram to the lift truck carriage by rotating the latch lever back to the closed position. [NOTE: The latch lever will only rotate back to the closed position if the latch aligns with a notch in the upper crossbar. Adjust the position of the carpet pole until the latch aligns with a notch.]

Use instructions:

CR-series rams function like crane. However, instead of using a hoist to lift loads, the pole rises and lowers as the forks of a lift truck are raised and lowered.

Engage a roll of carpet by driving the lift truck forward to insert the pole through the center of the roll. Drive forward until the roll contacts the roll stop (see FIGS. 1 and 2 on p. 3, 4). Raise the forks only as high as necessary to lift the roll of carpet off of the ground and to avoid contact with objects during transport. DO NOT leave a raised roll unattended. Always unload the carpet ram before leaving the forklift.

Inspections & Maintenance:

⚠WARNING If a problem is discovered during an inspection, restore the carpet ram to normal operating condition **BEFORE** using it again. DO NOT use the ram if it is structurally damaged in any way. Structural damage includes, but is not limited to, cracked welds, warping or deformation of the pole, carriage brackets, or frame members.

Inspections: perform the inspections explained below to ensure that the ram is in normal, safe operating condition when used.

Initial inspection — before a new or modified ram is used for the first time, inspect it to confirm normal condition.

After the first use, conduct the following 2 types of inspection:

a. **Frequent inspection**— Daily to monthly intervals.

The following items shall be inspected for defects at the intervals specifically indicated, including observation *during operation* for any defects which might appear between inspections. All deficiencies such as those listed shall be carefully examined to determine whether they constitute a safety hazard:

[Inspect daily] All functional operating mechanisms (pole, carriage brackets, lever latch, carriage weldment backplate, and all fasteners for maladjustment or damage that might interfere with proper operation. Inspect:

1. The surface of the ram for dirt or other matter;
2. Integrity of hardware and fasteners, including but not limited to bolts, nuts, pins, springs;
3. Normal operability of manually (by hand or foot) operated mechanisms;
4. Abnormal, unstable or noisy movement during use.
5. For looseness or excessive wear, damage, or indications of metal fatigue in any portion of the pole or the carriage backplate weldment. Examine the clamp mechanism (that receives and grips the end of the pole) and the carriage brackets (that attach the carpet pole to the forklift carriage) particularly closely.
6. Labels (see “Label placement diagram” on p. 8). Replace all damaged or unreadable labels.
7. The whole structure for corrosion or rusting/metal erosion.

b. **Periodic inspection** [29 CFR 1910.179(j)(1)(ii)(b)] — 1-to-12 month intervals.

Inspect the entire ram apparatus at intervals that correspond to its frequency of use, severity of service, and environment, or as specifically indicated below. Perform all of the applicable Frequent Inspection steps and carefully examine the unit for *any* the problems that appear below to determine whether they constitute a safety hazard:

- Deformed, cracked, or corroded members.
- Loose fasteners (bolts or rivets).

Carpet ram not in regular use:

In addition to frequent and periodic inspections, any ram which has been idle for a period of one month or longer must be given a thorough inspection before it is used again. An appointed person, whose approval is required before the unit may be used, should inspect the ram for all types of deterioration.

- If idle for a period of 1 month (or longer), but less than 6 months, perform a Frequent Inspection before returning it to service.
- A ram that has not been used for longer than 6 months shall be given a “Periodic [complete] inspection” before placing it in service.
- Standby rams shall be given a frequent inspection at least semi-annually (twice per year; 1 inspection every 6 months).

Annual performance evaluation: At least once per year, authorized inspection personnel should verify the soundness of the ram. Use it to lift a maximum rated load. Afterwards, conduct a Frequent Inspection to verify that the product is in normal operating condition.

Maintenance:

End-users should implement a maintenance program to ensure that the product functions properly and is adequately maintained. OSHA “General Industry” standards applied to “Powered industrial trucks,” 29 CFR 1910.178, describe official, recommended maintenance procedures. The following steps should be utilized in conjunction with those recommendations.

⚠️WARNING The end-user is responsible for selecting and training employees to work on the carpet pole. “Work on” refers to attaching, loading, cleaning, servicing, maintaining, or repairing the product. ONLY trained, authorized maintenance personnel or contractors should perform inspection, maintenance, or repair work.

Step 1: Tag the pole, “Out of Service.”

Step 2: Remove any dirt or other matter from all surfaces.

Step 3: Conduct a “Before each use” inspection. If deformity, corrosion, rusting, or excessive wear of structural members is found, DO NOT use the product.

Step 4: Perform all other necessary adjustments, replacements and/or repairs. DO NOT modify the boom.

⚠️WARNING DO NOT use the carpet pole if adjustments and/or repairs are incomplete! Return it to service ONLY after finishing all necessary repairs and adjustments. The reader should understand the significant difference between necessary adjustments and repairs, and modifications.

An “adjustment” is a simple correction that restores the boom to normal operating condition, such as tightening loose fasteners, or removing dirt or other debris from the surface. “Repair” refers to removing worn parts and installing replacement parts.

A “modification” is a change that alters the carpet pole from normal operating condition, like bending the structural members or removing a part or several parts. **NEVER** modify the boom without the express, written approval of Vestil. Modifications may render the device unsafe to use.

Step 5: Make a dated record of any repairs, adjustments and/or replacements.

Label Placement Diagram:

The product should always be labeled as shown in the diagram below. Replace any label that is damaged or not easily readable.

Label 985:

⚠️ WARNING	⚠️ ADVERTENCIA
<p>Serious personal injury might result if this product is installed or used improperly.</p> <ul style="list-style-type: none"> • This side UP. • ALWAYS install carpet ram according to instruction manual. • When installed correctly, bolts clamping pole to backplate are below pole. • DO NOT ride or sit on carpet ram. • DO NOT use carpet ram to push, pull, or drag another object. • DO NOT leave elevated roll of carpet unattended 	<p>Daños serios al personal podrían ser el resultado si este producto se instala o utiliza incorrectamente.</p> <ul style="list-style-type: none"> • Esta parte hacia ARRIBA • SIEMPRE instale el recojedor de alfombras de acuerdo con le manual de instrucciones • NO ande o se sienta en el recojedor de alfombras • NO use el recojedor de alfombras para empujar, tirar, o arrastrar ningun objeto • NO deje el elevado rollo de alfombra sin atender. <p style="text-align: right; font-size: small;">985</p>



Label 287; Model, serial no. capacity

MODEL/MODÉLO/MODÈLE _____

STATIC CAPACITY (evenly distributed) _____ lbs.

LA CAPACIDAD CONSTANTE (distribuida uniformemente) _____ kgs.

CAPACITÉ STATIQUE (distribuée régulièrement) _____ kgs.

SERIAL/SERIE/SÉRIE _____

287 REV 0812

LIMITED WARRANTY

Vestil Manufacturing Corporation (“Vestil”) warrants this product to be free of defects in material and workmanship during the warranty period. *Our warranty obligation is to provide a replacement for a defective original part if the part is covered by the warranty, after we receive a proper request from the warrantee (you) for warranty service.*

Who may request service?

Only a warrantee may request service. *You are a warrantee if* you purchased the product from Vestil or from an authorized distributor AND Vestil has been fully paid.

What is an “original part”?

An original part is a part used to make the product as shipped to the warrantee.

What is a “proper request”?

A request for warranty service is proper if Vestil receives: 1) a photocopy of the Customer Invoice that displays the shipping date; AND 2) a written request for warranty service including your name and phone number. Send requests by any of the following methods:

Mail
Vestil Manufacturing Corporation
2999 North Wayne Street, PO Box 507
Angola, IN 46703

Fax
(260) 665-1339
Phone
(260) 665-7586

Email
sales@vestil.com

In the written request, list the parts believed to be defective and include the address where replacements should be delivered.

What is covered under the warranty?

After Vestil receives your request for warranty service, an authorized representative will contact you to determine whether your claim is covered by the warranty. Before providing warranty service, Vestil may require you to send the entire product, or just the defective part or parts, to its facility in Angola, IN. The warranty covers defects in the following *original* dynamic components: motors, hydraulic pumps, electronic controllers, switches and cylinders. It also covers defects in *original* parts that wear under normal usage conditions (“wearing parts”): bearings, hoses, wheels, seals, brushes, batteries, and the battery charger.

How long is the warranty period?

The warranty period for original components is 90 days. The warranty period begins on the date when Vestil ships the product to the warrantee. If the product was purchased from an authorized distributor, the period begins when the distributor ships the product. Vestil may extend the warranty period for products shipped from authorized distributors by *up to* 30 days to account for shipping time.

If a defective part is covered by the warranty, what will Vestil do to correct the problem?

Vestil will provide an appropriate replacement for any *covered* part. An authorized representative of Vestil will contact you to discuss your claim.

What is not covered by the warranty?

1. Labor;
2. Freight;
3. Occurrence of any of the following, which automatically voids the warranty:
 - Product misuse;
 - Negligent operation or repair;
 - Corrosion or use in corrosive environments;
 - Inadequate or improper maintenance;
 - Damage sustained during shipping;
 - Collisions or other incidental contacts causing damage to the product;
 - Unauthorized modifications: DO NOT modify the product IN ANY WAY without first receiving written authorization from Vestil. Modification(s) might make the product unsafe to use or might cause excessive and/or abnormal wear.

Do any other warranties apply to the product?

Vestil Manufacturing Corp. makes no other express warranties. All implied warranties are disclaimed to the extent allowed by law. Any implied warranty not disclaimed is limited in scope to the terms of this Limited Warranty.

